

A Loudspeaker With Intelligence

EVOi.324

User's Guide

Introducing The Next Generation of Installed Sound

evo



Safety Information	1
Introduction	2
Design Overview	3
Features	
EVOi.324 Front/Top	4
EVOi.324 Rear	5
Hook-Up Details	6
Applications	7
Loudspeaker Basics	8
Coverage Angles	9
Aiming	10
Multiple Speakers	10
Delay Speakers	11
Rectangular Rooms	12
Fan Shaped Rooms	15
Painting	17
Installation	18
Troubleshooting	20
Appendix	21
Technical Data	22
Warranty	23

IMPORTANT SAFETY INFORMATION - READ THIS CAREFULLY

This equipment has been tested and found to comply with the following European and international standards for Electromagnetic Compatibility and Electrical Safety:

Radiated Emissions (EU): EN55022B (1992)
RF Immunity (EU): IEC801-3 (1994)
Electrostatic Discharge(EU): IEC801-2 (1984)
Fast Transients(EU): IEC801-4 (1988)
Electrical Safety (EU): EN60065 (1994)
Electrical Safety(USA): UL6500/ETL (1996)
Electrical Safety(CAN): CAN/CSA-E65/ETLc (1996)



Before using the apparatus read these instructions, follow all instructions, heed them and keep in a safe place.

Clean only with a damp cloth. Do not block any of the ventilation openings. Install in accordance with the manufacturer's instructions.

Do not defeat the safety purpose of the grounding type plug. A grounding plug has two blades and a third grounding prong. The third prong is provided for your safety. When the provided plug does not fit into your outlet, consult an electrician for replacement of the obsolete outlet.

Protect the power cord from being walked on or pinched particularly at plugs, convenience recepticals and the point where they exit from the apparatus.

Only use attachments/accessories specified by the manufacturer.

Unplug this apparatus during lightning storms or when not in use for a long time.

WARNING – TO REDUCE THE RISK OF FIRE OR SHOCK, DO NOT EXPOSE THIS APPARATUS TO RAIN OR MOISTURE.

DO NOT REMOVE COVERS, NO USER SERVICABLE PARTS INSIDE, REFER SERVICING TO QUALIFIED SERVICE PERSONNEL.

THIS EQUIPMENT MUST BE GROUNDED.



**DO NOT EXPOSE
TO RAIN OR MOISTURE**



**NE PAS EXPOSER A
LA PLUIE NI L'HUMIDITE**

IT SHOULD NOT BE NECESSARY TO REMOVE ANY PROTECTIVE GROUND OR SIGNAL CABLE SHIELD CONNECTIONS TO PREVENT GROUND LOOPS. ANY SUCH DISCONNECTIONS ARE OUTSIDE THE RECOMMENDED PRACTICE OF JBL PROFESSIONAL AND WILL RENDER ANY EMC OR SAFETY CERTIFICATION VOID.

For continued compliance with international EMC legislation ensure that all input and output cables are wired with the cable screen connected to Pin 1 of the XLR connectors. The input XLR Pin 1 is connected to the chassis via a low value capacitor, providing high immunity from ground loops while ensuring good EMC performance.

I N T R O D U C T I O N

WELCOME

Thank you for purchasing an EVOi.324 Intelligent Powered Loudspeaker. Not only is this the most compact 1300 watt powered loudspeaker, it is also the world's first loudspeaker with built-in intelligence. The integrated digital technology allows it to manage its own performance and through the use of the optional EVOi.net Speaker System Controller, adapt sonically to virtually any environment in which you place it. The result is an architecturally designed installation powered loudspeaker system that provides great sound with minimum stress.

PACKAGE CONTENTS

Upon unpacking the EVOi.324 please take note of the contents as listed below. If you are missing any of the items listed below, please contact your dealer as soon as possible.

- 1 x EVOi.324 Speaker System
- 1 x User's Guide with Warranty and Tech Note No. 14, Volume 1
- 1 x Accessory bag which includes:
 - 1 x AC Cord
 - 1 x Eyebolt Kit (3 x Shoulder Eye Bolts, 3 x Washers)
 - 2 x Small Rubber Feet
 - 1 x Large Rubber Foot
 - 1 x Washer



EVOi.324

D E S I G N O V E R V I E W

The EVOi.324 has been designed specifically for fixed installation applications. EVO is intended to be used where high quality state-of-the-art sound reinforcement is required, in venues such as performing arts centers, worship spaces, educational multi-purpose rooms and other civic venues.

It has been engineered to provide premium performance with minimal visual impact. EVOi.324 speakers adapt to internal décor with a paintable surface and to low ceilings by offering the same performance in a vertical and horizontal configuration.

Installation and setup are quick and simple to understand. This is the fundamental principle of the EVO system, whereby the majority of problems in system installation and set-up are eliminated because the most complex elements have already been designed into the loudspeaker.



EVOi.324

FEATURES

EVOi.324 FRONT/TOP

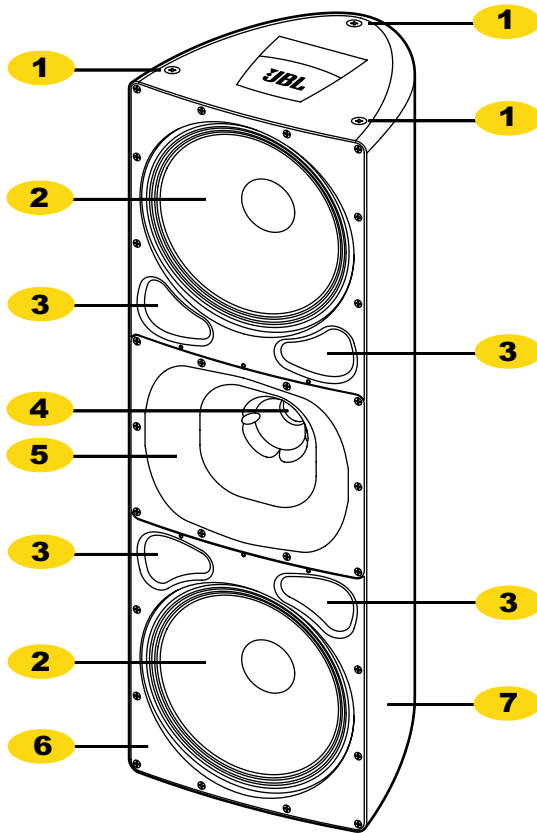

Figure 1 - EVOi.324 Front & Top
(Grill removed for clarity)

1 JBL Eyebolt System

Located on the top (and bottom) is our standard JBL eyebolt system to accommodate ceiling attachment (and floor mounting system, see Foot Kit, page 19), when required.

2 14" LF/MF Transducers

Each 14-inch, LF (Low Frequency) and LF/Mid carbon-fiber cone transducer features our patented dual-coil, dual-gap Neodymium Differential Drive (NDD™) technology for 1/5th the weight of conventional ferrite transducers with twice the power handling. Moreover, each transducer is driven by its own 600 watt D-class (digital) amplifier.

3 Thermomaster® Vents

Each respective baffle vent, woofer motor, and basket are all linked via the same thermal transfer path for maximum heat dissipation. Taking heat away from the voice coil effectively reduces power compression. The harder the system works, the better it cools.

4 2430 Compression Driver

The JBL 2430 neodymium large-format compression driver has a 1.5-inch exit and 3-inch voice coil with 100 watt power handling. The revolutionary neodymium motor structure results in an extremely compact and lightweight HF (High Frequency) transducer, weighing only 2.5 lbs. The JBL 2430 driver is powered by an internal 100 watt linear amplifier.

5 Aluminum Waveguide

The aluminum waveguide effectively couples the JBL 2430 driver to the outside world. It works with the LF/MF and LF transducers and our Filtered Array Technology (FAT™) to achieve a constant 80° x 80° horizontal and vertical coverage pattern.

6 Integrated Baffle

Our integrated transducer baffle and inertia grounding straps are designed to lock all the components together, maximizing acoustic output. The entire baffle area acts as an open thermal window through which heat is allowed to escape.

7 SMC Enclosure

The rear enclosure, fabricated from SMC (Sheet Molding Compound), is in the form of a 2nd-order geometric design for inherent strength, acoustic architecture, and transparent aesthetics.

SMC Grille (not shown)

It looks like cloth, but it's actually an anti-resonant, SMC-reinforced, expanded steel grill, with an enhanced high frequency spreading effect.



EVOi.324 REAR

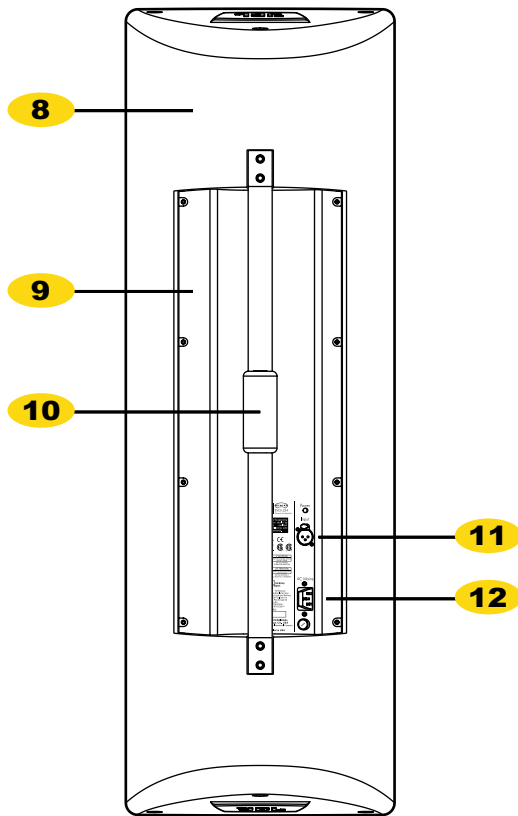

Figure 2 - EVOi.324 Rear

8 Compact Design

EVOi.324's design has been dedicated to applications requiring a permanent sound reinforcement solution. For a 1,300-watt Intelligent Powered Speaker System, it weighs only 65 pounds (29.5 kg) and stands barely 42" (1.07 meters) tall.

9 D-Class Amplifier

Each EVOi.324 includes two digital amplifiers that are extremely efficient. The energy from the power supply is rapidly switched into each loudspeaker. The audio signal is created as modulated pulses with switching rates many times faster than the highest audio frequency. Because energy only flows when needed, losses are substantially reduced as compared to an equivalent sized conventional amplifier.

10 Handle/Grip

As an aid for setup, the EVOi.324 is equipped with a built-in carrying handle and grip.

11 XLR Audio / Communication Input

EVO's 'brain' is found in the EVOi.324. All transducer controls and complex computational system functions take place on the DSP (Digital Signal Processor) circuit board within the aluminum housing. Working in tandem with the optional EVOi.net, each EVOi.324 adapts to its acoustic environment by generating its own test sequence, including Auto-EQ and Delay Set settings. With Anti Feedback Control, it also discriminates between feedback and program music.

Hook-up is easy – simply use a standard XLR signal cable to connect from an open EVOi.net Male XLR output (or output from a mixer – see page 6) to the EVOi.324's Female XLR. No other cables are required. An internal BiDAT™ (Bi-directional Data-over-Audio Transceiver) communication system ensures that correct instructions are sent and messages received across the signal cables.

12 Switch-Mode Power Supply

EVOi.324 uses a compact, lightweight, and highly efficient digital power supply that does not require a large, heavy toroidal transformer. This low-loss technology utilizes digital modulation to regulate and supply the voltage necessary to drive 1,300 watts of power amplification.

Insert the enclosed power cord into the IEC connector to supply the specified AC power. (See "Hook-up Details" on page 6 for more information.) The removable fuse protects internal circuits. When replacing it, be sure to use the same type as specified.



H O O K - U P D E T A I L S

AUDIO AND AC POWER CONNECTIONS

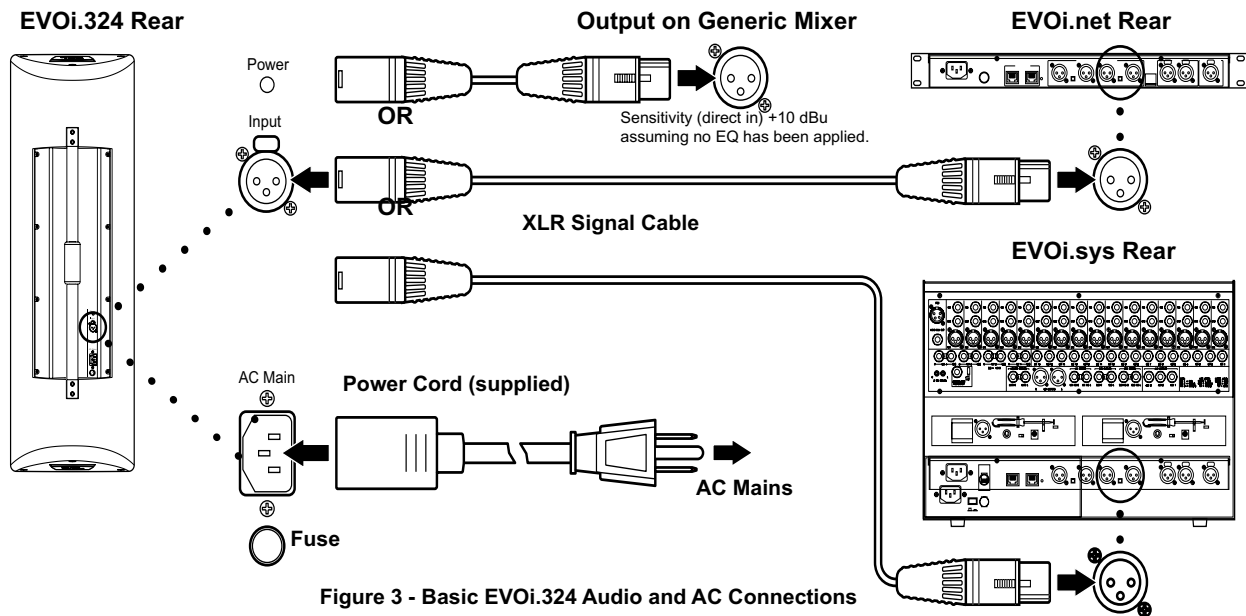

Figure 3 - Basic EVOi.324 Audio and AC Connections

Maximum Drive Level = +10 dBu * Sensitivity

There are three simple audio hook-up options: all require the use of high quality balanced signal cable with a Male XLR connector. EVOi.324 requires a drive level of +10 dBu (sensitivity = +10 dBu assuming no external equalization has been applied to the signal) for maximum performance. Hooking a microphone directly to the input will NOT drive it sufficiently. The output of a standard mixer, EVOi.net or EVOi.sys should provide the optimum drive level. (See the Sensitivity Chart in the Appendix, page 21)

Power Requirements

IMPORTANT: Each individual EVOi.324 is an extremely powerful system and is quite capable of drawing peak currents of up to 18 amps. Please consult a qualified electrician for correct installation and power connection. For more information, see AC Requirements on page 21.

CAUTION: to reduce the risk of fire, replace fuse with same type and rating: **ATTENTION:** utiliser un fusible de rechange de meme type de:

115V~ T6.3A/250V~
230V~ T3.15A/250V~

Power Cycle (Boot-up) Times

EVOi.324's internal DSP (Digital Signal Processor) circuit board includes software applications. Like any device operating software programs, there is a "boot-up" time lag before EVOi.324 becomes fully operational. **The audio signal will be muted until the loudspeaker is fully booted up. This should take approximately 20 seconds.**

Upon connecting AC mains, the green power indicator will illuminate. After approximately 20 seconds there will be a very quiet click as the system releases the mute. Upon power disconnection, the green power indicator will flash several times, however signal shut-down is instantaneous. In summary, boot-up time is approximately 20 seconds and shut-down time is 0 seconds.

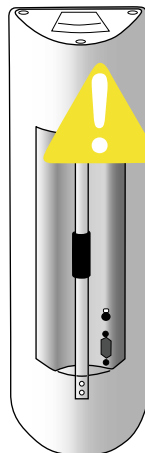

WARNING! When EVOi.324 is on, the amplifier heatsink will get hot even when no signal is being passed. This is normal operation for D-Class amplifiers.



* 0 dBu = 0.775 Volts; +10 dBu = 2.45 Volts

INTENDED APPLICATIONS

EVO Loudspeaker Systems have been optimized for small to mid-size venues, where a pair will sufficiently reinforce sound for an audience of up to five hundred people. They have been designed with specific applications in mind: schools and sports facilities; places of worship; and performance venues. Typically the program of events are quite varied and high quality reinforcement is required for speech, live music and recorded music playback. Figures 4-7 below show some typical type venues and an identifiable area that requires sound reinforcement, we identify this as the listening area. This section describes how to optimize the placement and position of the EVO Loudspeaker in these typical applications in order that the entire listening area receives good sound. These are very simple instructions and are for ideal situations. As guidelines, they are approximate and it may not be possible to follow them in all situations. In the end, final aiming decisions must be based on what is actually heard when walking the room. Use your ears.

Schools and Sports Facilities

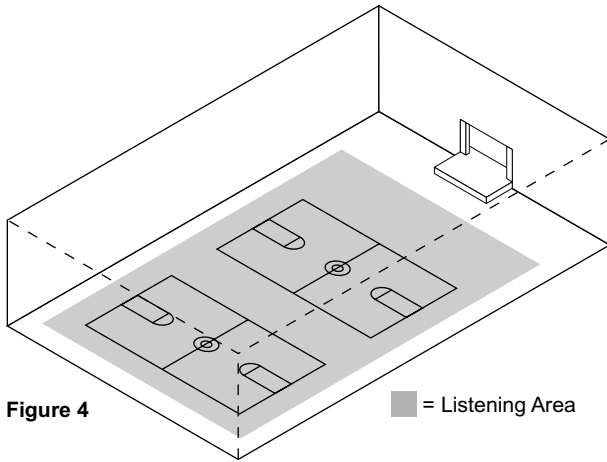
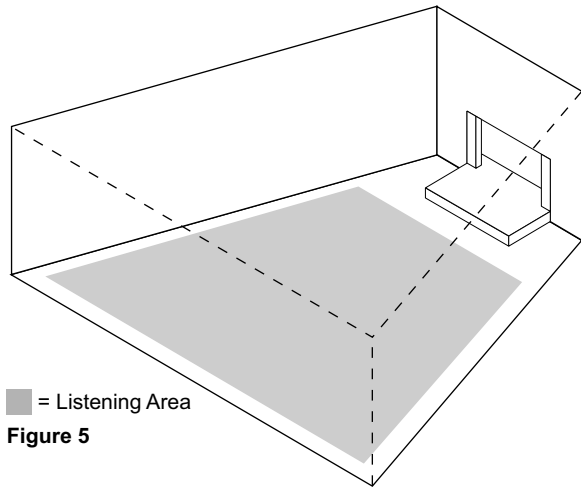

Figure 4

■ = Listening Area

Performance Venues



■ = Listening Area
Figure 5

Places of Worship Rectangular-Shaped Room

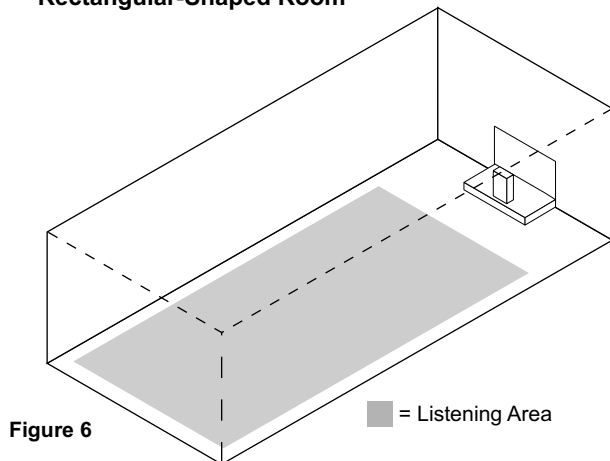
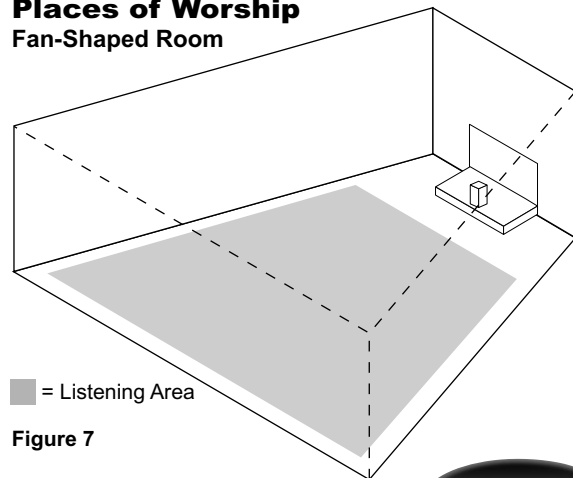

Figure 6

■ = Listening Area

Places of Worship Fan-Shaped Room



■ = Listening Area
Figure 7



LOUDSPEAKER BASICS

EVO Sound System Design Basics

The primary function of a sound reinforcement system is to make sure that all of the listeners in a given audience area are able to understand the speech and/or lyrics that are being reinforced. The *intelligibility* of a loudspeaker system is a measure of how “understandable” its output is. Intelligibility is optimized when the sound radiated from the loudspeaker is primarily directed to the audience areas and away from microphones and reflective surfaces in the room.

In order to ensure that the radiated sound is directed primarily to the audience areas, great care must be taken in deciding on loudspeaker placement and aiming. Understanding a loudspeaker’s *coverage angles* and the proper application of those coverage angles is the first step towards designing a great sound reinforcement system.

EVOi.324 Coverage Angles

The majority of the sound coming from the EVOi.324 loudspeaker radiates at an angle of 80 degrees in the speaker’s horizontal (side-to-side) plane and 80 degrees in the speaker’s vertical (top-to-bottom) plane. (Figures 8 and 9.)

Horizontal Coverage Angles

Horizontal Coverage = 80°

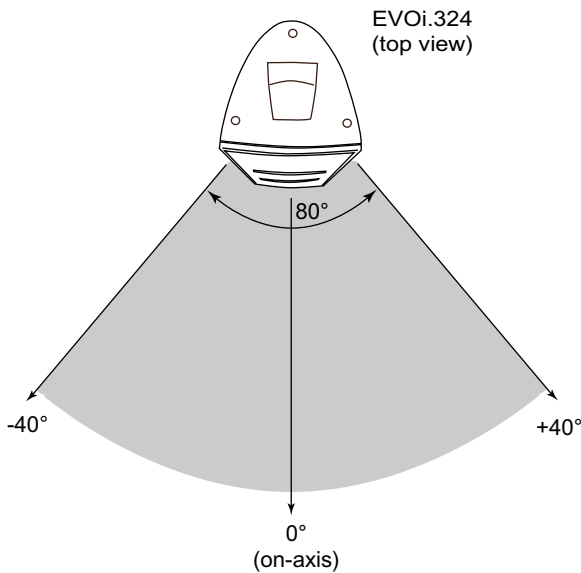

Figure 8 - 80° Horizontal Coverage



Vertical Coverage Angles

Vertical Coverage = 80°

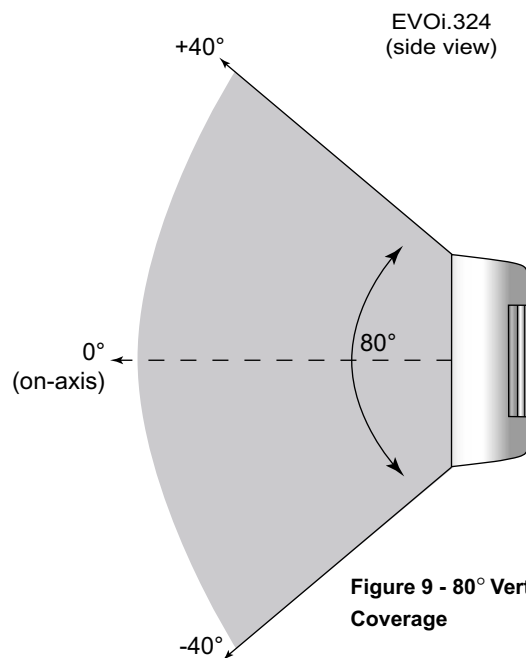

Figure 9 - 80° Vertical Coverage

EVOi.324 Coverage Angles

Placing this 80° x 80° speaker up in the air and pointing it towards an audience area will result in a defined *area of coverage*.

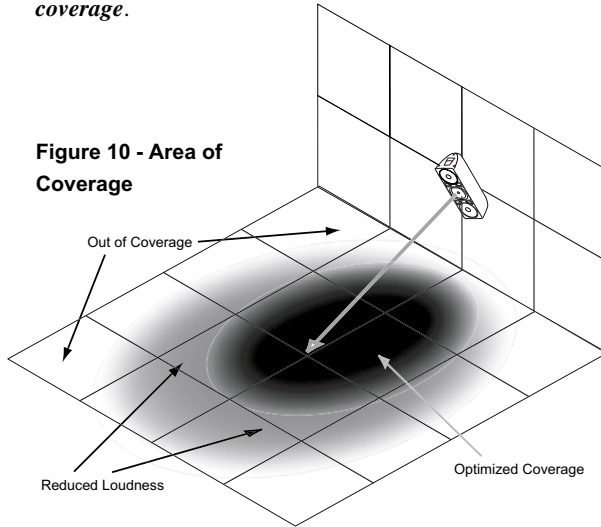

Figure 10 - Area of Coverage

Note that this area of coverage actually includes three different areas: an area of “optimized coverage” (black); an area of “reduced loudness” (gray); and an area “out of coverage” (white).

Understanding the optimum performance of the EVO Loudspeaker through the use of a simple Throw Ratio and Aiming guide line will help you achieve optimized coverage over your defined listening area.

The Throw Ratio

Based on its area of coverage performance, the EVOi.324 has a height-to-depth **Throw Ratio** of 1:3. This Throw Ratio can be used to optimally position the loudspeaker. For example, if the EVOi.324 is installed at a height of 10', it will “throw” to a distance of 30' away from the loudspeaker and hence provide optimized coverage up to 30' away.

Refer to Table 1 and Figure 11 below to identify either:

- The throw (optimized coverage distance), for a given fixed (pre-determined) height above the floor.
- The installation height necessary to provide the desired throw (optimized coverage distance).

Throw *	Installation Height	Aiming Point (Distance from Loudspeaker)	Downward Tilt Aiming Angle
30'	10'	20'	26.6°
40'	13' 4"	26' 8"	26.6°
50'	16' 8"	33' 4"	26.6°
60'	20'	40'	26.6°
70'	23' 4"	46' 8"	26.6°
80'	28' 8"	53' 4"	26.6°
90'	30'	60'	26.6°
100'	33' 4"	66' 8"	26.6°
110'	36' 8"	73' 4"	26.6°
120'	40'	80'	26.6°

* Optimized Coverage Distance

Table 1 : Throw Ratio

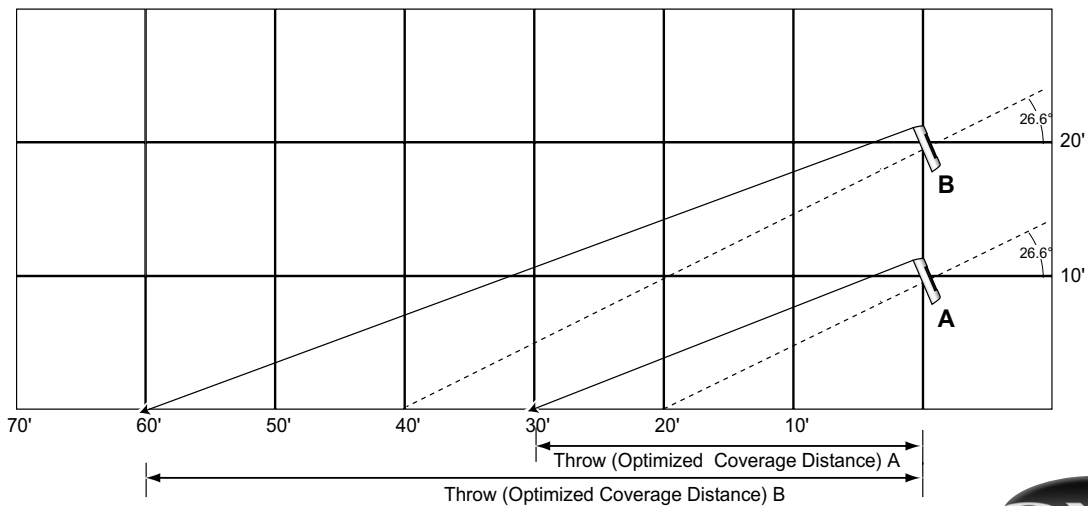

Figure 11 - Throw Ratio



LOUDSPEAKER BASICS

Aiming EVO

Once the optimum height of the EVO loudspeaker has been identified it needs to be aimed to achieve the desired coverage area. The point at which to aim is derived from a simple height-to-depth *aiming ratio* of 1:2. For example, if the EVOi.324 is installed at a height of 10', it will "throw" to a distance 30' away provided it is aimed to a point 20' away. Refer to Table 1 and Figure 11 on page 9.

Maximum Performance Guideline

You may have noted from Table 1 that the guide does not provide figures above a 40' installation height. Above a height of 40' the useful throw and optimized coverage area will not grow, in fact it will probably start to deteriorate depending on the natural acoustics of the room.

The guidelines below can be used to determine the maximum performance achievable for a given loudspeaker height above the listening area.

Program Requirement	Maximum Height	Maximum Throw
Speech only	40'	120'
Speech + acoustic music	40'	120'
Amplified live music	20'	60'
Loud, playback music	20'	60'

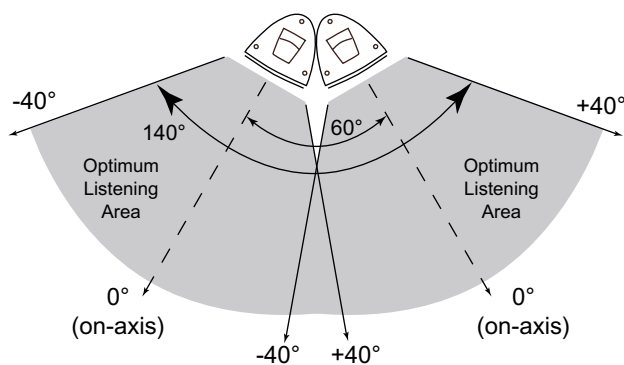

Figure 14 - Optimum Splay Angle

Using More Than One Speaker

Stereo and Arrays

So far we have discussed the simplest sound reinforcement system configuration, a single EVO loudspeaker. Most applications will require the use of more than one EVOi.324, either because a stereo Left – Right effect is required (see Figure 12)...

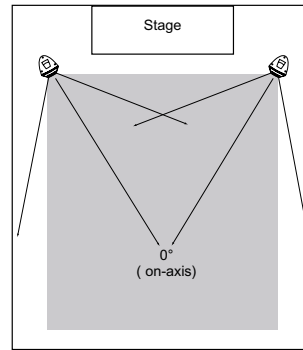

Figure 12 - Stereo Left Right Placement

...or additional coverage is required (e.g. for a wider listening area). In this case, two EVOi.324s could be arrayed together as in Figure 13.

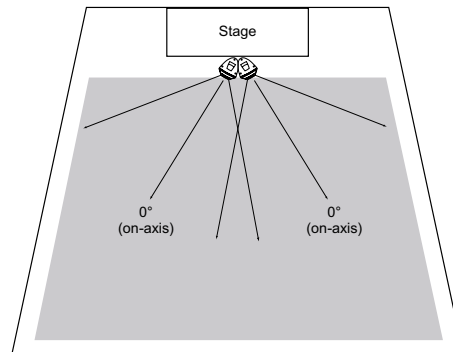

Figure 13 - Mono Two Speaker Array

Figure 14 to the left shows the optimum "Splay Angle" of 60° for a combined optimum horizontal coverage of 140°.

Exactly the same guidelines that are used for one loudspeaker can be used for more than one: the Throw Ratio and Aiming Ratio.



LOUDSPEAKER BASICS

When to use Delay Speakers

The use of more than one EVOi.324 may be necessary in venues with extremely long listening areas.

For example if the listening area is 120' in depth and the required performance is for "Loud Playback Music" the Maximum Performance Guideline on page 10 indicates a maximum 20' installation height. This will provide 60' of throw. To cover the remaining 60' of listening area, a second auxiliary/delay speaker is required (see Figure 15).

Note that the sound from the delay speaker must be "in sync" with the sound from the main speaker. This is achieved by appropriately delaying the audio signal arriving at the delay speaker and also by reducing its overall output level. While these adjustments typically require the use of complex measurement equipment, expensive delay devices and years of audio experience, they can be made automatically through the use of the optional EVOi.net controller.

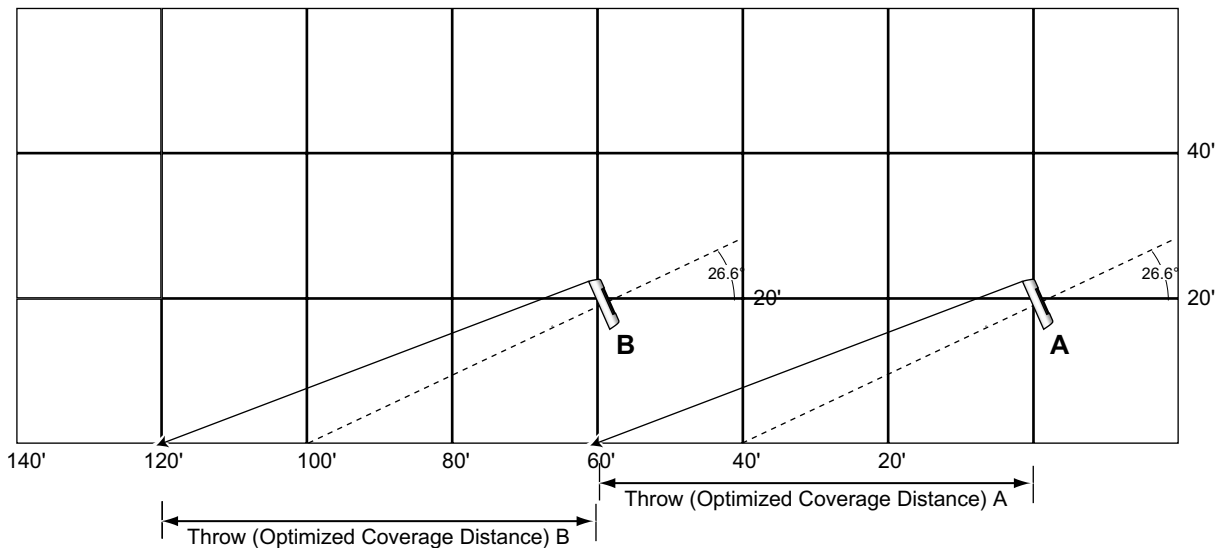

Figure 15: Basic Delay Speaker Placement



A P P L I C A T I O N S

As a guide this section provides some typical configurations for EVOi.324 installations, the approximate locations of each EVOi.324 and the aiming position in the room. Please note that when the installation requires the additional support of an auxiliary (Delay) EVOi.324s to cover larger listening areas, the use of EVOi.net is highly recommended as this will access the automated “delay-set” feature.

EVOi.324s IN RECTANGULAR ROOMS

Small Rectangular Room: 1 Main (Mono)

This is the simplest configuration. In this example, figure 16, one EVOi.324 will cover the entire listening area. Stereo is not required, as this system is predominantly used to reinforce speech only. The EVOi.324 is positioned 20' above the floor and aimed to a point 40' away on the central axis of the room. Optimum coverage will be provided up to 60 feet away.

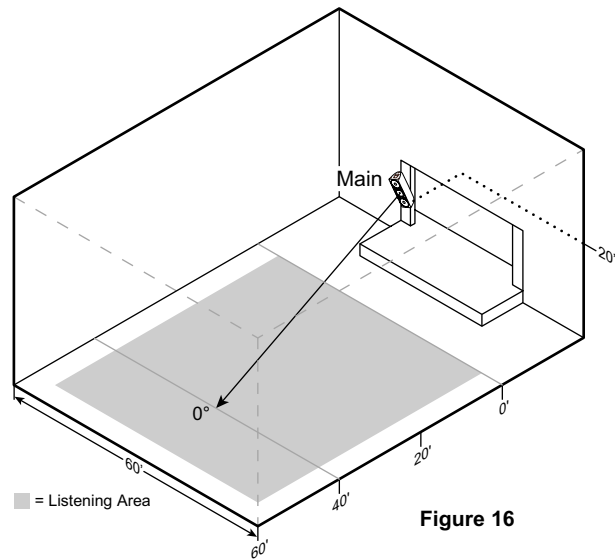

Figure 16

Longer Rectangular Room: 1 Main (Mono) + 1 Delay (Mono)

For a longer room additional coverage will be required to cover the back rows of the listening area. This can be achieved using an additional auxiliary (Delay) EVOi.324 as shown in Figure 17.

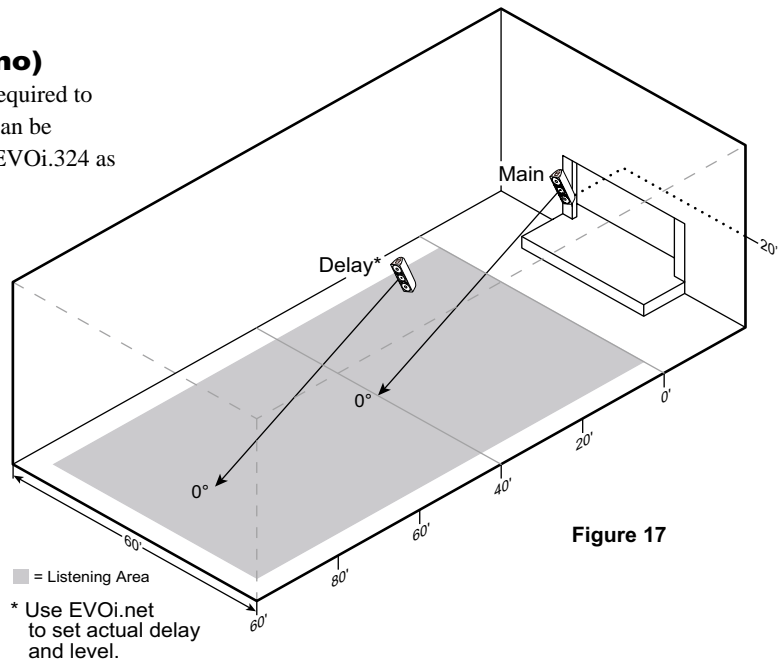

Figure 17



EVOi.324s IN RECTANGULAR ROOMS

Small/Wider Rectangular Room: 2 Main (Stereo)

For a wider room or where a stereo program is required each EVOi.324 should be aimed according to the 1:3 “throw ratio” described in the previous section (page 8 & 9). In this example, the EVOi.324s are positioned 20’ high and aimed 40’ away. They will provide optimum coverage up to 60’ away. In addition, they should both be aimed at a single point 40’ away, the central axis of the room, as seen in Figure 18.

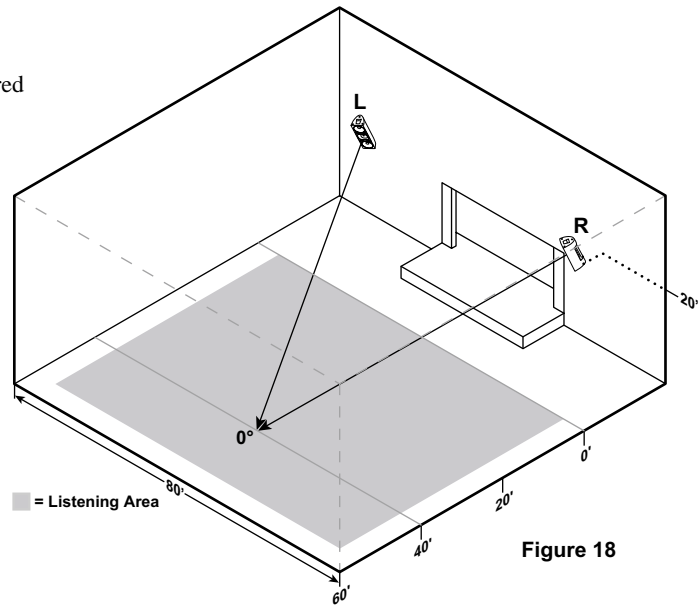

Figure 18

Longer/Wider Rectangular Room: 2 Main (Stereo) + 2 Delay (Stereo)

For additional coverage in a longer room, two more auxiliary (Delay) EVOi.324s can be used, positioned and aimed as shown in Figure 19.

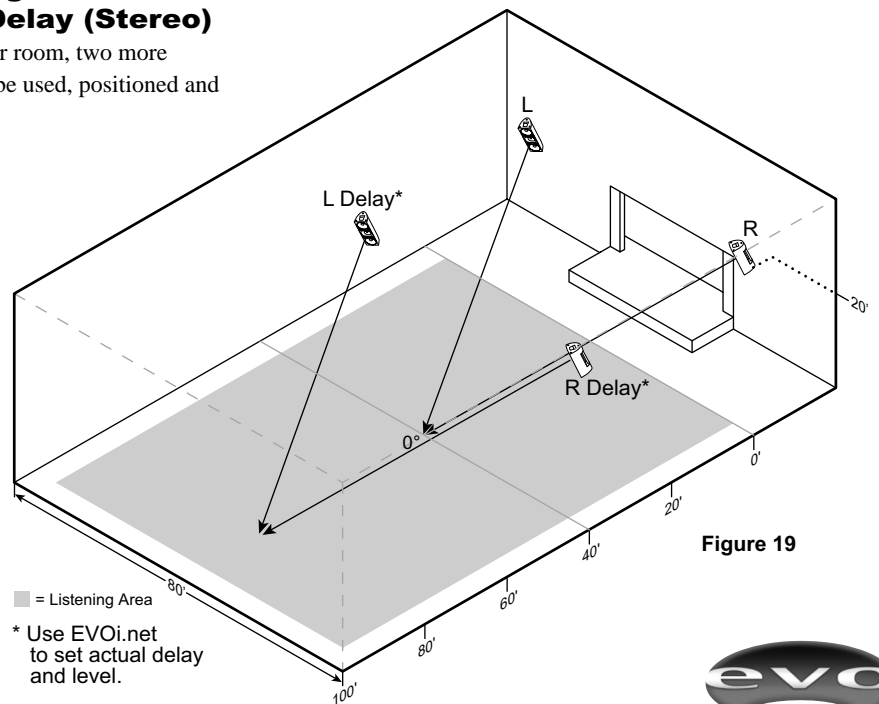

Figure 19



EVOi.324s IN RECTANGULAR ROOMS

Larger/Wider Rectangular Rooms: 2 Main (Mono Array) + 2 Delay (Mono Array)

In a wide room where a stereo program is not necessary the Main and Delay EVOi.324s can be configured into Arrays for broader coverage and supplied with a mono signal. (See page 10 for array specifics.) Figure 20 shows such an application.

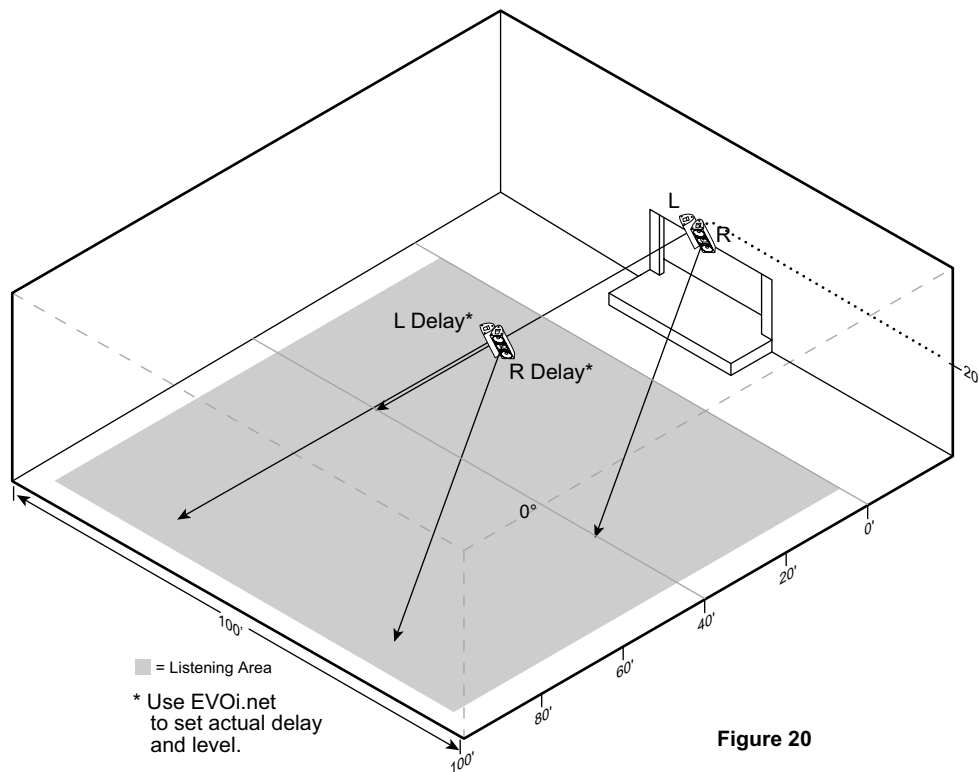

Figure 20



EVOi.324s IN FAN SHAPED ROOMS

Small Fan Shaped Room: 1 Main (Mono)

Like the small rectangular room, a simple configuration of one EVOi.324 will provide enough coverage for the entire listening area. Stereo is not required, as this system is predominantly used to reinforce speech only. The EVOi.324 is positioned 20' above the floor and aimed to a point 40' away on the central axis of the room. Optimum coverage will be provided up to 60' away as shown in Figure 21.

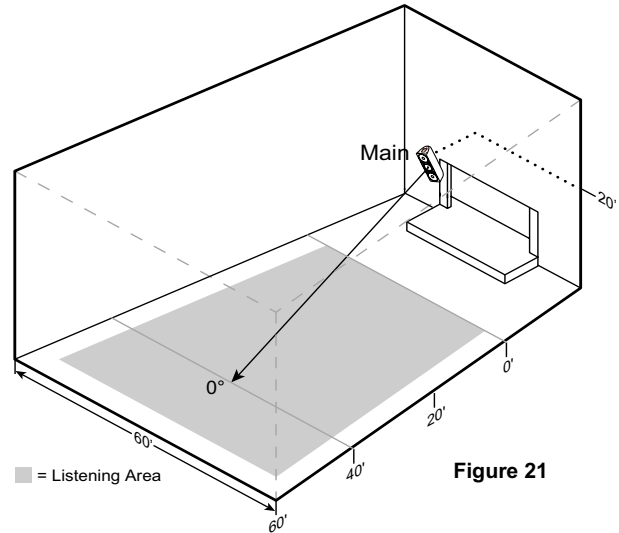

Figure 21

Medium Fan Shaped Room: 2 Main (Mono Array)

In a wider room where a Mono program is required two EVOi.324s can be arrayed together to provide wider coverage. These are positioned as described in Figure 22 below.

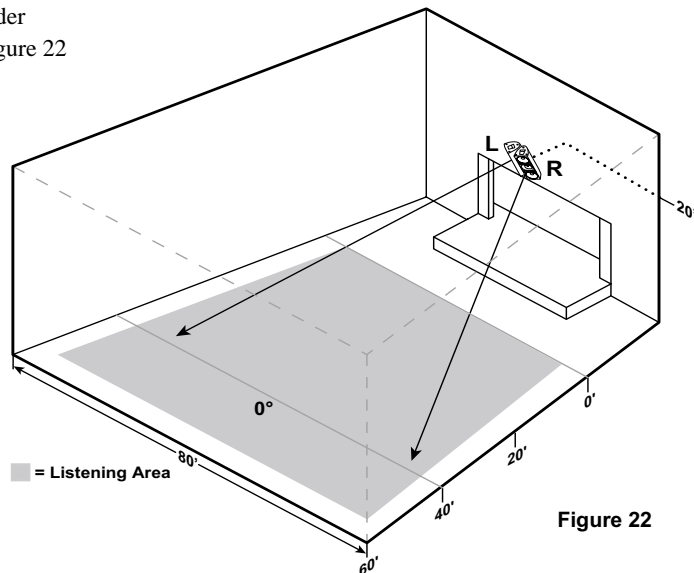

Figure 22



EVOi.324s IN FAN SHAPED ROOMS

Large Fan Shaped Room: 2 Main (Mono Array) + 2 Delay (Mono)

A larger version of the previous example, Figure 23, illustrates the positioning of two Delay EVOi.324s to cover the listening area that falls outside the optimum coverage of the Main EVOi.324 Array.

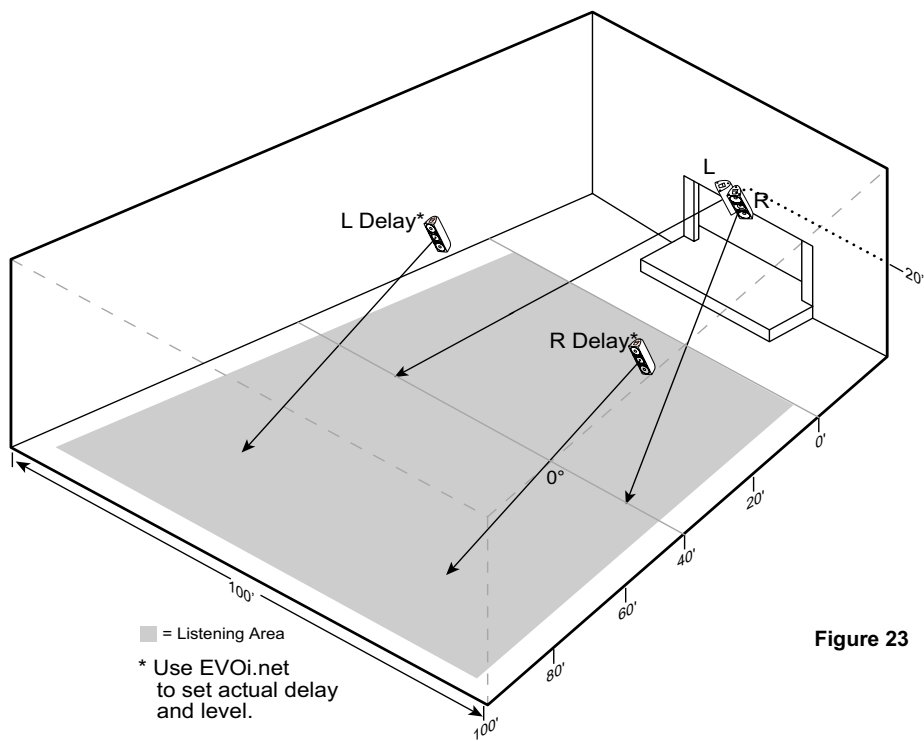

Figure 23



EVOi.324 is readily paintable. The SMC (Sheet Molding Compound) provides a lightly textured surface that any standard household or industrial paint readily adheres to. The result is a sound reinforcement system that is able to blend unobtrusively into the decor of its environment.

Instructions for Painting:

1. It is strongly recommended that EVOi.324 be partially disassembled to obtain optimum results. This requires removing the grill, the handle bar, and suspension point placeholder screws.

- A. Remove the grill screw covers by gently prying off.
- B. Remove six grill retain screws.
- C. Remove four allen head screws from the grill frame.
- D. Remove the grill taking care to keep the grill and grill supports together.
- E. Remove all six suspension placeholder screws.
- F. Remove the four allen screws retaining the handle bar and remove the bar.

2. Prepare all surfaces by wiping off dust and cleaning with a damp cloth. It may be necessary to use a mild household cleaner to remove grease.

3. Carefully mask the aluminum electronics enclosure on the back of the speaker. **IT SHOULD NOT BE PAINTED.** Removal of the electronics enclosure should only be done by qualified service personnel.

4. Carefully mask the baffle area. Avoid getting paint on the loudspeaker cones or in the waveguide. It's not a good thing.

5. Apply as many coats of paint as is required. Standard household or industrial paints (i. e. waterbased latex or enamel) will provide the best results. Spraying many thin coats will provide the best results.

6. Assemble the EVOi.324 in reverse order as described in Step One.

Figure 24 - Exploded View for Painting

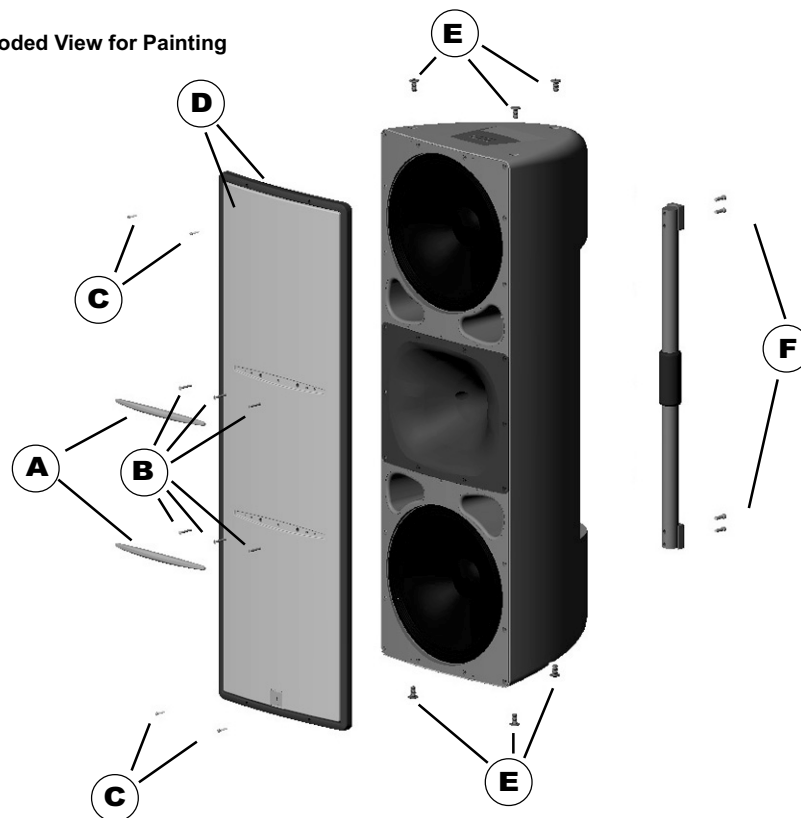

I N S T A L L A T I O N

Overview

EVOi.324 has been designed to be permanently installed. An eyebolt kit has been provided to facilitate suspension from above: a ceiling, a beam or overhang. EVOi.324 weighs 65 pounds (29.5 Kg) and attaching this loudspeaker to a surface is a task that should not be taken lightly. Always consult a qualified person.

Suspension

WARNING !! Suspending this system should be done by qualified persons following safe rigging standards. For more information, please refer to the JBL Technical Note Volume 1, Number 14 – Basic Principles for Suspending Loudspeaker Systems.

Before suspending an EVOi.324, be sure to inspect all components for cracks, deformations, corrosion, and/or missing or damaged parts that could reduce the strength and safety of the installation.

Perform all calculations to ensure that all components are used within their rated work load before suspending an EVOi.324. Remember the weakest component determines the size and safety of the entire installation.

There are 3 suspension points on the top and bottom of EVOi.324, two toward the front of the enclosure and one to the rear. Pull tests at a certified test facility have documented non-catastrophic failure at 450 – 550 pounds for each individual front suspension point and 1000 pounds for the rear suspension point.

It is recommended that EVOi.324 be either suspended:

1. Equally from both of the front suspension points together, or
2. From the rear suspension point, with the addition of a safety cable to another suspension point.

For both recommendations, assuming a 7:1 safety factor, the load on the suspension points should NEVER be greater than 142.8 pounds (67.8 Kg).

For Example: Maximum Load Rating divided by EVOi.324 Net Weight = The number of speakers in a vertical array.

$$142.8 \text{ lb (67.8 Kg)} / 65 \text{ lb (29.5 Kg)} = 2.1$$

Therefore only two EVOi.324s may be used in a vertical array if they are suspended from the points located on the top of the enclosure in either recommendations 1 and 2 stated above.

Eyebolt Kit

Parts Included:

- 3 Shoulder Eyebolts
- 3 Washers
- 1 Suspension Advisory and Tech Note

Installing Eyebolts:

1. Remove suspension placeholder screws.
2. Coat each eyebolt with thread-locking material (e.g., Loctite #2 or equivalent).
3. Using the included washers as stand-offs, thread the eyebolts into the open holes and tighten.

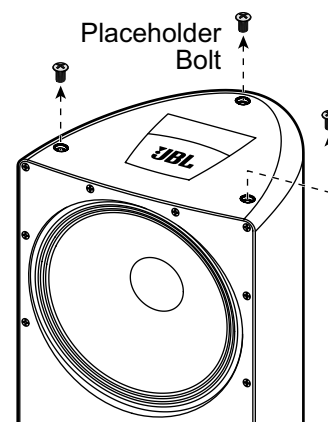

Figure 25 - Remove Placeholder Bolts

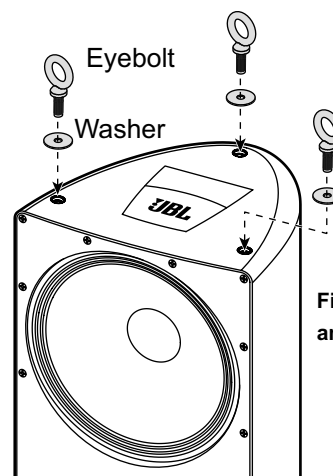

Figure 26 - Install Washers and Eyebolts



Foot Kit

The Foot Kit must be utilized if EVOi.324 is to be used “Free Standing”. It provides a much more stable base and also a mechanism that compensates for the shape and angle of the bottom of the enclosure.

Parts Included:

- 2 x Small Rubber Feet
- 1 x Large Rubber Foot, threaded with nut
- 1 x Washer

Installing Feet:

- i. Remove suspension insert screws from the bottom of the enclosure.

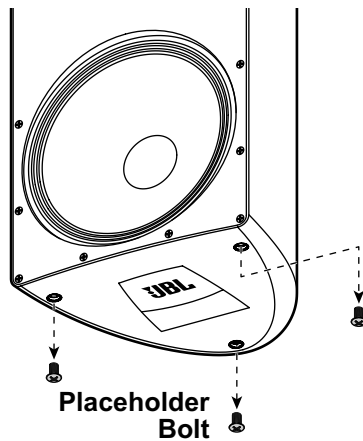

Figure 27 - Remove Lower Placeholder Bolts

- ii. Using two of the removed suspension placeholder screws attach the small rubber feet to the front suspension positions. Please note that there is an orientation to the small rubber feet which compensates for the angle of the enclosure surface.
- iii. Place the large washer over the rear suspension position. Make sure the nut is threaded onto the large rubber foot. Then insert the threaded portion through the washer and into the rear suspension position.

- iv. Screw the large rubber foot into the suspension position for the required aiming angle. For example, screw it all the way in and EVOi.324 will aim up slightly. Unscrewing it will begin to tilt EVOi.324 down.
- v. **Important:** Once the large rubber foot is positioned correctly tighten the nut onto the washer. This will ensure the weight is transferred to the enclosure and not the suspension insert.

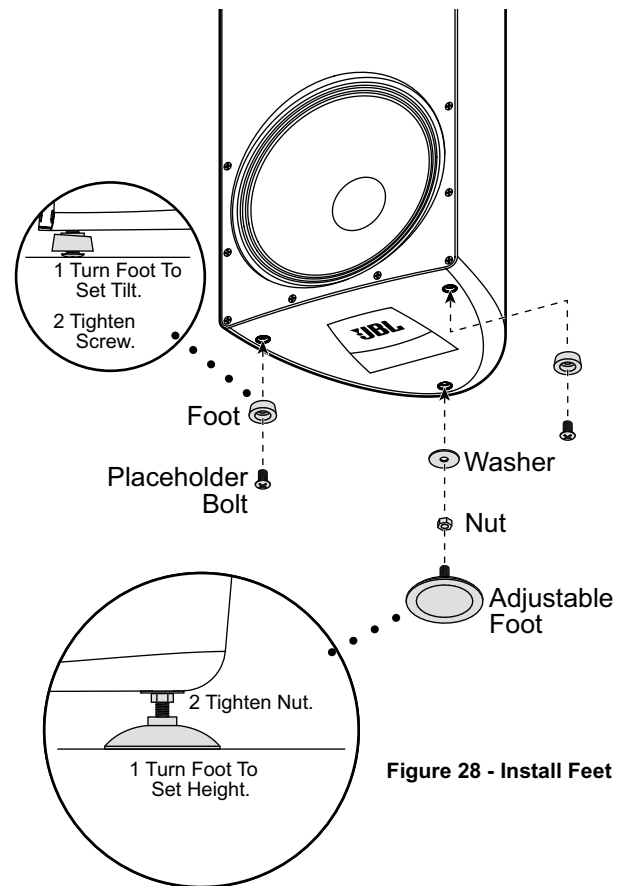

Figure 28 - Install Feet



T R O U B L E S H O O T I N G

The EVOi.324 loudspeaker system has been precision engineered for optimum performance with a minimum of maintenance and outside intervention.

AC Power

The EVOi.324 speaker contains a high-powered amplifier system. Due to the remote locations likely for install, there is no power switch. Application of the AC Mains power will result in the EVOi.324 starting up and initializing (boot process takes about 20 seconds). There is a slight power draw even when EVOi.324 is not passing audio (approximately equivalent to a 100W light bulb (see AC Power requirements page 21). It may be desirable to place a switch on its circuit. This switch should be appropriately rated and installed by a competent electrician in full compliance with all applicable national and local electrical codes.

1. EVOi.324 doesn't power up:

- i. Is it plugged in?
- ii. Is the AC Mains circuit adequate for system and energized?

Due to the highly efficient nature of the electronics, there will be a direct correlation between signal level and current draw. While it may be possible to start multiple systems on one AC circuit, continued high level operation may result in occasional brown-outs (see *AC Power Requirements* on page 21).

2. The Power LED is Flashing:

- i. The AC Main voltage is inadequate or out of the rated range (see AC Power requirements page 21).
- ii. The AC Mains is not appropriate for the model (i.e. 120V model for 120V service). Check the voltage stated on the rear input label and return to the Dealer if incorrect.
- iii. The fuse may have blown. CAUTION: to reduce the risk of fire, replace the fuse with the same type and rating.
- iv. If none of the above then immediately contact your Dealer.

3. EVOi.324 powers up, the LED on rear panel lights up, but doesn't pass audio:

- i. Less than 20 seconds have passed. Wait for a couple of moments as EVOi.324 Boots-up.
- ii. Check that there is audio signal present:
 - Is there a signal cable connected? If so, check that it is not defective.
 - Is there signal coming out of the mixer?
 - Is EVOi.net attached? (See EVOi.net manual.)
- iii. If none of the above then immediately contact your Dealer.

4. The system doesn't get any louder no matter how much the input signal is turned up:

- i. Is it really loud already? Built-in limiters are specially calibrated to prevent damaging levels to the individual speakers in EVOi.324. These limiters are designed to be as transparent as possible while still providing necessary protection functionality. It doesn't get any louder because it is working, protecting itself!

5. The sound system is making a terrible noise:

- i. If a microphone is being used in the system you may be hearing feedback. Turning down the level of the microphone and/or repositioning it may help. Using EVOi.net you can start the Anti Feedback control built into EVOi.324.
- ii. Is tape deck playback level up? Electrical feedback may be present. Try lowering the tape deck playback level. Check that the tape deck is not connected to the record outputs.



AC Power Requirements

In the United States, the EVOi.324 is supplied with an Edison type plug. For other countries, the correct plug must be used in accordance with the local requirements. For Europe and the rest of the world the correct AC supply lead will be supplied.

Voltage Requirements

EVOi.324 will operate continuously provided the AC Voltage falls within the following ranges:

Standard AC Voltage	Voltage Range	Frequency
120v	+/- 10%	50/60Hz
230v	+/- 10%	50/60Hz

Brown-out Conditions

If the voltage falls below this range, the EVOi.324 will 'brown-out'. During 'brown-out' the audio signal will momentarily mute during very high level program. Should the supply voltage permanently remain below this supply voltage, then the EVOi.324 will shut down. When the AC supply falls within the above stated ranges, EVOi.324 will switch on again, and operate normally.

To avoid 'brown-out' EVOi.324 should be operated with an AC supply that adequately falls within the above stated ranges.

Current Requirements

EVOi.324 will not draw a continuous current. Acting as a dynamic load on the AC supply, the current drawn will vary dependant on the operating level, e.g. quiet levels and loud levels in the program.

Understanding the amount of current drawn is essential when using EVOi.324.

The EVOi.324 is capable of drawing peak currents of up to 18 Amps. Any cabling used should be of a suitable gauge to reflect this. Inadequate cabling can cause large voltage drops over distance and potentially cause 'brown-out'.

ALWAYS CONSULT A QUALIFIED ELECTRICIAN

EVOi.324 Sensitivity Chart

Electrical Input		Acoustic Output
dBu	Volts (AC RMS)	Measured SPL (dB re: 20uPa)
-25	0.04	91
-20	0.08	96
-15	0.14	101
-10	0.25	106
-5	0.44	110
0	0.78	116
5	1.38	118
8	1.95	120
10	2.45	122
101 dB = Equivalent 1w/1m Specification		



TECHNICAL DATA

EVOi.324 Specifications

Frequency Range (-10 dB):	40 Hz - 18 kHz
Freq. Response (-3 dB):	48 Hz - 16 kHz
Horizontal Coverage (-6 dB):	80° (averaged 500 Hz -16 kHz)
Vertical Coverage (-6 dB):	80° (averaged 500 Hz -16 kHz)
Directivity Factor (Q):	11.4 (averaged 500 Hz -16 kHz)
Directivity Index (DI):	10.6 dB (averaged 500 Hz - 16 kHz)
Equivalent Sensitivity:	101 dB (-15 dBu @ 1 meter = 1 watt/meter)
Dimensions (H x W x D):	42 x 13.9 x 15.2" (1067 x 353 x 386.2 mm)
Net Weight:	65 lbs. (29.48 Kg)
Low Frequency Driver:	14" NDD, Carbon Fiber Cone, Dual 2" Voice Coils, Integral Thermomaster
Low Frequency/Mid Driver:	14" NDD, Carbon Fiber Cone, Dual 2" Voice Coils, Integral Thermomaster
High Frequency Driver:	2430, Large Format, 1.5" Exit Compression Driver with a Neodymium Motor, 100 Watt 3" Encapsulated Voice Coil, Aluminum Diaphragm
Waveguide:	Aluminum thermally coupled to 2430 via "silpad" gasket
Amplifier Power Low Frequency:	440 Hz load ref = 6 Ohms, Input = 1.4 Vrms/5.14 dBu, Output = 300W rms, THD<0.3%
Max. Continuous Output:	330 Wrms (with Limiters)
Burst Output:	600 Wrms
Signal-to-Noise Ratio:	>90 dB A weighted
Amplifier Power LF/Mid:	440 Hz load ref = 6 Ohms, Input = 1.4 Vrms/5.14 dBu, Output = 300 Wrms, THD<0.3%
Max. Continuous Output:	330 Wrms (with Limiters)
Burst Output:	600 Wrms
Signal-to-Noise Ratio:	>90 dB A weighted
Amplifier Power HF:	3 kHz load ref = 8 Ohms, Input = 3.2 Vrms/12.3 dBu, Output = 35 Wrms, THD<0.2%
Maximum Continuous Output:	50 Wrms (with Limiters)
Burst Output:	100 Wrms
Signal-to-Noise Ratio:	>90 dB A weighted
Audio Connectors:	Balanced XLR
LF Crossover Frequency:	250 Hz
LF/Mid Crossover Frequency:	1.25 kHz
HF Crossover Frequency:	1.25 kHz
Limiting:	Dynamic Amplifier Clip Prevention
Transducer EQ type:	Parametric



WARRANTY

JBL Limited Warranty

The JBL Limited Warranty on professional loudspeaker products (except for enclosures) remains in effect for five years from the date of the first consumer purchase. JBL amplifiers are warranted for three years from the date of original purchase. Enclosures and all other JBL products are warranted for two years from the date of original purchase.

Who Is Protected by This Warranty?

Your JBL Warranty protects the original owner and all subsequent owners so long as: A.) Your JBL product has been purchased in the Continental United States, Hawaii or Alaska. (This Warranty does not apply to JBL products purchased elsewhere except for purchases by military outlets. Other purchasers should contact the local JBL distributor for warranty information.); and B.) The original dated bill of sale is presented whenever warranty service is required.

What is Covered by the JBL Warranty?

Except as specified below, your JBL Warranty covers all defects in material and workmanship. The following are not covered: Damage caused by accident, misuse, abuse, product modification or neglect; damage occurring during shipment; damage resulting from failure to follow instructions contained in your Instruction Manual; damage resulting from the performance of repairs by someone not authorized by JBL; claims based upon any misrepresentations by the seller; any JBL product on which the serial number has been defaced, modified or removed.

Who Pays for What?

JBL will pay all labor and material expenses for all repairs covered by this warranty. Please be sure to save the original shipping cartons because a charge will be made if replacement cartons are requested. Payment of shipping charges is discussed in the next section of this warranty.

How to Obtain Warranty Performance

If your JBL product ever needs service, write or telephone us at JBL Incorporated (Attn: Customer Service Department), 8500 Balboa Boulevard, PO. Box 2200, Northridge, California 91329 (818/893-8411). We may direct you to an authorized JBL Service Agency or ask you to send your unit to the factory for repair. Either way, you'll need to

present the original bill of sale to establish the date of purchase. Please do not ship your JBL product to the factory without prior authorization. If transportation of your JBL product presents any unusual difficulties, please advise us and we may make special arrangements with you. Otherwise, you are responsible for transporting your product for repair or arranging for its transportation and for payment of any initial shipping charges. However, we will pay the return shipping charges if repairs are covered by the warranty.

Limitation of Implied Warranties

ALL IMPLIED WARRANTIES, INCLUDING WARRANTIES OF MERCHANTABILITY AND FITNESS FOR PARTICULAR PURPOSE, ARE LIMITED IN DURATION TO THE LENGTH OF THIS WARRANTY.

EXCLUSION OF CERTAIN DAMAGES

JBL'S LIABILITY IS LIMITED TO THE REPAIR OR REPLACEMENT, AT OUR OPTION, OF ANY DEFECTIVE PRODUCT AND SHALL NOT INCLUDE INCIDENTAL OR CONSEQUENTIAL DAMAGES OF ANY KIND. SOME STATES DO NOT ALLOW LIMITATIONS ON HOW LONG AN IMPLIED WARRANTY LASTS AND/OR DO NOT ALLOW THE EXCLUSION OF INCIDENTAL OR CONSEQUENTIAL DAMAGES, SO THE ABOVE LIMITATIONS AND EXCLUSIONS MAY NOT APPLY TO YOU. THIS WARRANTY GIVES YOU SPECIFIC LEGAL RIGHTS, AND YOU MAY ALSO HAVE OTHER RIGHTS WHICH VARY FROM STATE TO STATE.

JBL Professional Contact Information

Mailing Address
JBL Professional
8500 Balboa Blvd.
Northridge California 91329

Customer Service
Monday through Friday 8:00am - 5:00pm Pacific Coast Time

In the U.S.A. (800) 8JBLPRO (800.852.5776)
On the World Wide Web: <http://www.jblpro.com>



N O T E S



24

EVOi.324

I N D E X

- AC Requirements 6, 20, 21
 - Power Supply 5
- Accessories 2
 - Eyebolt Kit 2, 4, 18
 - Foot Kit 2, 4, 19
- Aiming 10
- Appendix 21
- Applications 7
 - School and Sports Facilities 7
 - Performance Venues 7
 - Places of Worship 7
- Components
 - Amplifiers 5
 - High Frequency 4
 - Low Frequency 4
 - Mid Frequency 4
- Cooling 4
 - Thermomaster Vents 4
- Coverage Angles 9
- Delay Speakers 11-16
- Design Overview 3
- Eyebolt Kit 2, 4, 18
- Inputs 5
- Introduction 2
- Fan Shaped Rooms 15-16
- Features 4
 - EVOi.324 Front/Top 4
 - EVOi.324 Rear 5
- Foot Kit 2, 4, 19
- Hanging Speakers 18
- Hook-Up Details 6
- Installation 18
- Loudspeaker Basics 8
- Maximum Performance Guideline 10
- Multiple Speakers 10
- Package Contents 2
- Painting 17
- Performance Venues 7
- Places of Worship 7
- Power Cycle Times 6
- Problems 20
- Rectangular Rooms 12-14
- Safety Information 1
- School and Sports Facilities 7
- Speaker Placement 9-16
- Specifications 22
- Technical Data 22
- Thermomaster Vents 4
- Throw Ratio 9
- Troubleshooting 20
- Warranty 23





A Harman International Company

JBL Professional • 8500 Balboa Boulevard • Northridge, CA 91329

www.jblpro.com

Part # 981-00057-00

© Copyright 2001 JBL Professional • Printed in the USA